

BST 330-60 M



The DELTA BST series are photovoltaic modules made of premium materials. At a low solar irradiance intensity, DELTA BST generate more electricity than standard solar modules with similar characteristics. During the manufacture of DELTA BST modules, a multi-stage quality control of components and processes is performed, including the IV test and a two-stage EL test before and after lamination. DELTA BST stand for high performance, durability and advanced technologies.

Cells

Technology	Mono crystal
Cell thickness	220 μ m
Number of cells	60 (6 x 10)
Cell size	156 x 156
Quality class	Grade A

Temperature coefficients

NOCT*	45 \pm 2 $^{\circ}$ C
Of power (P_{max})	-0.4%/ $^{\circ}$ C
Of voltage (U_{oc})	-0.29%/ $^{\circ}$ C
Of current (I_{sc})	0.05%/ $^{\circ}$ C
Operating and storage temperature	-40 \div 85 $^{\circ}$ C

*NOCT – normal operating temperature of solar module

Electrical parameters (STC)*

Peak electrical power (P_{max})	300 W
Tolerance	+3%
Nominal voltage (U_{nom})	24 V
Voltage at maximum power point (U_{mp})	32.7 V
Current at maximum power point (I_{mp})	9.17 A
Short-circuit current (I_{sc})	9.78 A
Open-circuit voltage (U_{oc})	39.8 V
Maximum series fuse rating	15 A
Cell efficiency	21.3%
Module efficiency	18.48%

Mechanical characteristic

Module dimensions	1640 x 990 x 35 mm
Weight	19 kg
Front glass	Tempered non-reflecting glass 3.2 mm
Frame	Anodized aluminum
Terminal box	IP 68
Connectors	MC4
Cable length	900 mm
Output cable	4 mm ²
Number of diodes	3
Wind load	5400 Pa

*Standard measurement conditions (STC): light density 1000 W/m², air mass AM = 1.5, nominal temperature 25 $^{\circ}$ C

Solar module arrangement

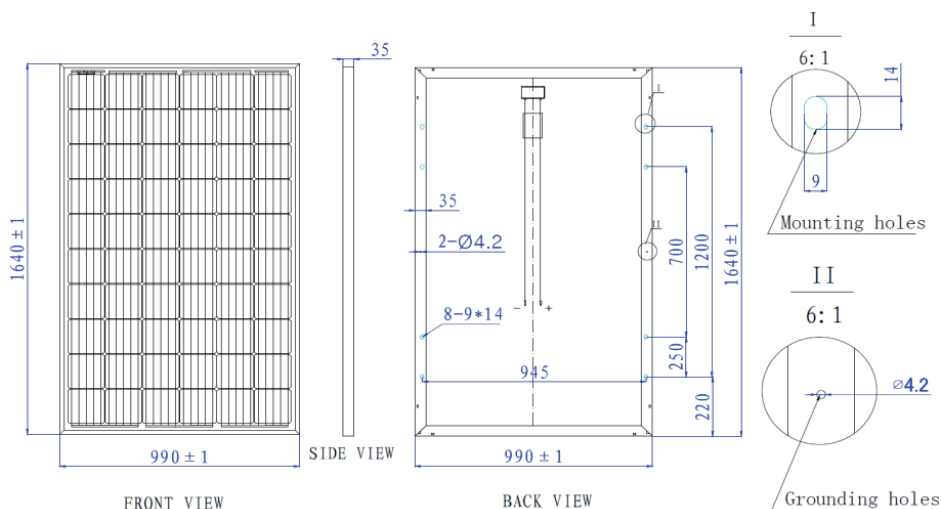

ATTENTION! The solar module should be installed and connected by a qualified technician with the corresponding access level. While connecting the solar module, strictly observe the connection polarity. Be sure to use a solar charge controller to charge the battery and power load. Before using the module, read the manual carefully.

Power voltage current curve at different temperature

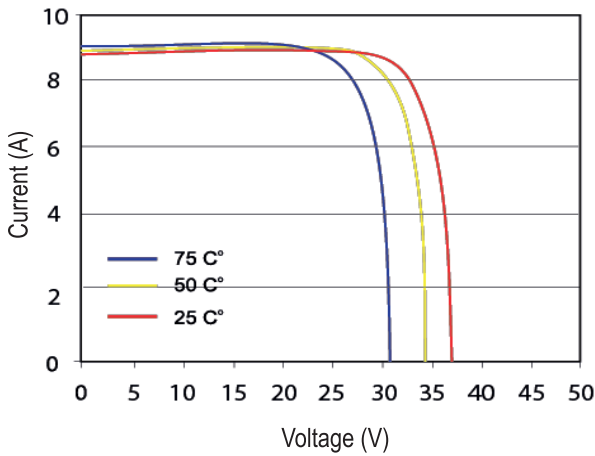

I-V curves at sun of 330-60 M at different irradiance

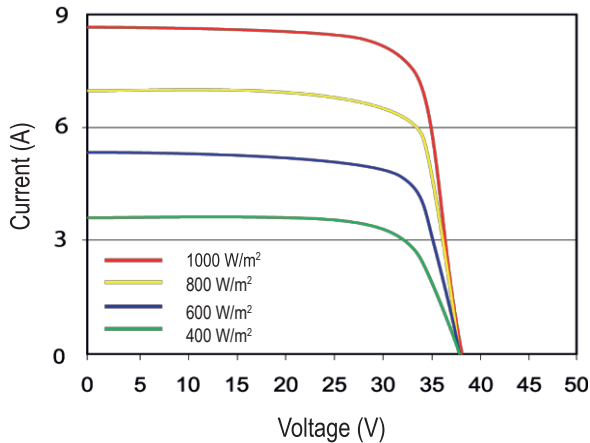

Advantages of DELTA BST series modules



High production standards

The quality control of BST modules complies with international standards IEC61215 and IEC61730, and also includes an extended procedure containing 74 quality control points. Particular attention is given to the quality of raw materials.



Higher electric-power generation

The preset power reserve is guaranteed to be higher than the nominal up to +3%. High power generation rates during shading or cloudy weather.



High efficiency

Cell efficiency 21.3%
Module efficiency 18.48%



Resistance to loads

The module can withstand high wind loads (up to 2400 Pa) and snow loads (up to 5400 Pa).



International management system

The products are manufactured and certified in accordance with ISO9001 standard.



Fire and chemical resistance

High resistance to salt and ammonia. Made of non-combustible materials.



Reliability

Not subject to the effect of PID (potential induced degradation)

Warranty

- The warranty for the solar modul is 10 years and does not cover any damages caused by mechanical, thermal or other external influences.
- Delta Solar guarantees that more than 90% of the declared nominal power will be retained for 12 years. 80% on the declared nominal power will be retained for 25 years.

Forecasted power conservation of the solar module

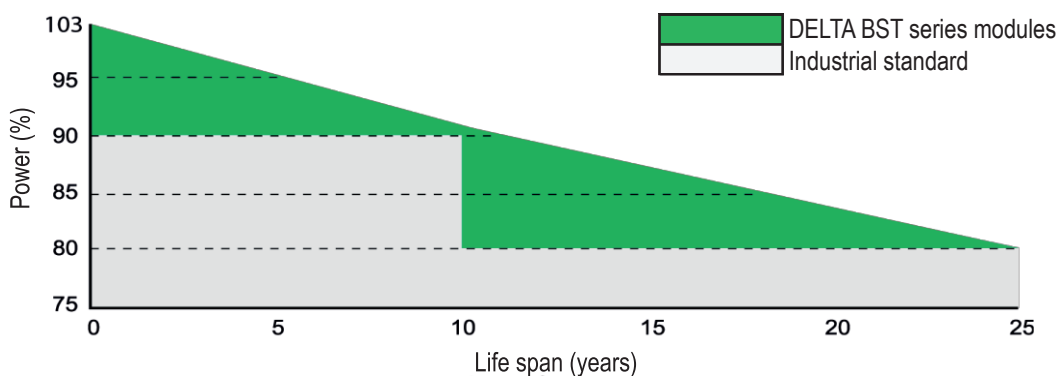

Our products are constantly being improved, so we reserve the right to make changes without prior notice.

